

# G45QS | Canopy Set

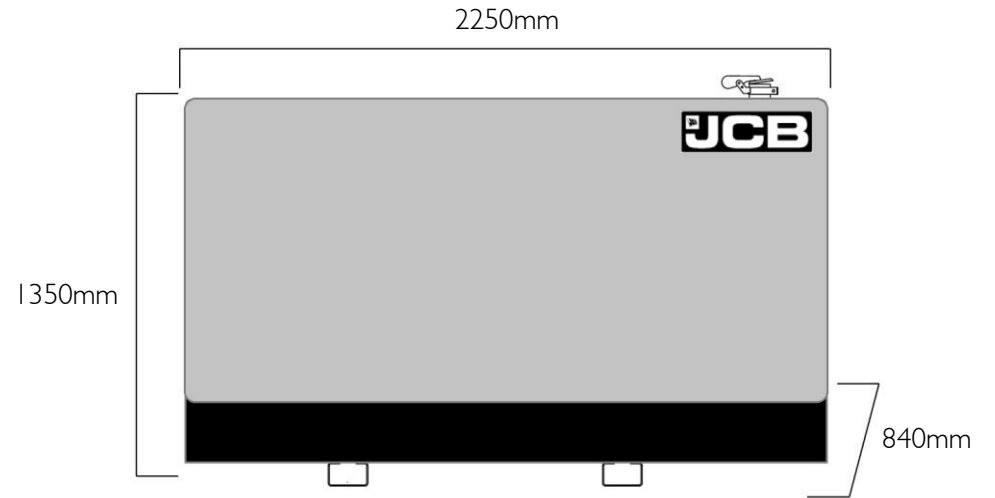

**DIESEL GENERATOR**

**FUEL OPTIMISED**

## ELECTRICAL

| Frequency (Hz) | Phases | Voltage (V) | Prime |      | Standby |      | MCB Rating (A) | Minimum ATP Rating (A) | Rated Speed (RPM) |
|----------------|--------|-------------|-------|------|---------|------|----------------|------------------------|-------------------|
|                |        |             | kVA   | kW   | kVA     | kW   |                |                        |                   |
| 50             | 3      | 400/230V    | 40.7  | 32.5 | 44.8    | 35.8 | 63             | 60                     | 1500              |

## POWER FACTOR

|         |     |
|---------|-----|
| 3 Phase | 0.8 |
| 1 Phase | 1   |

## MAXIMUM LOAD IMPACT\*

|     |       |
|-----|-------|
| kVA | 33.00 |
| kW  | 26.40 |

\*With 20% voltage and 10% frequency deviation @ 50Hz, 400V

## ALL RATINGS ARE TO STANDARD REFERENCE CONDITIONS ISO 8528

**Prime:** This rating is for the supply of continuous electrical power, at variable load, in lieu of commercially purchase power. There is no limitation on the annual hours of operation and 10% over load power can be supplied for 1 hour in 12.

**Standby:** This rating is for the supply of continuous electrical power, at variable load, in the event of a utility power failure. No overload is permitted.

**Stage IIIa** models are only emissions compliant at 50Hz Prime Power in accordance with 97-68EC.

## CANOPY/SKID

|  |   |
|--|---|
| Lockable Maintenance Access Doors              | ● |
| Control Panel Viewing Window                   | ● |
| Fork Pockets                                   | Δ |
| Single Lift Point                              | Δ |
| Bunding  | Δ |
| Open Frame                                     | Δ |
| High Density Fire Retardant Foam               | ● |
| Yellow Paint                                   | ● |
| White Paint                                    | Δ |
| Standard: ●    Not Available: x    Optional: Δ |   |

## ALTERNATOR ECP32 M 4

|                                 |                                     |
|---------------------------------|-------------------------------------|
| Poles                           | 4                                   |
| Winding Connections             | Star                                |
| Insulation                      | Class H                             |
| Enclosure                       | IP23                                |
| Exciter System                  | Self-regulating brushless           |
| Voltage Regulator               | AVR                                 |
| Steady State Voltage Regulation | +/- 1.0%                            |
| Bearing                         | Single bearing sealed               |
| Coupling                        | Flexible disc                       |
| Cooling                         | Direct drive centrifugal blower fan |
| Coating                         | Winding Protection Grey             |

## STARTING SYSTEM

|                     |    |      |
|---------------------|----|------|
| Starter Motor       | kW | 2.00 |
| Battery Capacity    | Ah | 110  |
| Number of Batteries |    | 1    |
| Auxiliary Voltage   | V  | 12   |

## ENGINE

|                          |           |                        |
|--------------------------|-----------|------------------------|
| <b>1500 RPM</b>          |           |                        |
| Output Rating (PRP)      | kW        | 36.00                  |
| Output Rating (Standby)  | kW        | 41.00                  |
| Manufacturer and Model   |           | Kohler/JCB KDI 2504 TM |
| Fuel                     |           | Diesel                 |
| Injection                |           | Direct                 |
| Aspiration               |           | Turbo Charged          |
| Cylinders                |           | 4                      |
| Bore and Stroke          | mm        | 88 x 102               |
| Displacement             | L         | 2.482                  |
| Cooling                  |           | Water                  |
| Engine Oil Specification |           | API CH4-SAE 10W40      |
| Compression Ratio        |           | 11.5 : 1               |
| Engine Oil Capacity      | L         | 11.30                  |
| Coolant Capacity         | L         | 7.60                   |
| Governor                 |           | Mechanical             |
| Air Filter               |           | Single paper element   |
| Engine Oil Consumption   | 100% Load | 0.1% of fuel consumed  |

## FUEL SYSTEM

|                             |   |       |
|-----------------------------|---|-------|
| Diesel Specification        |   | EN590 |
| Standard Fuel Tank Capacity | L | 81    |

## FUEL CONSUMPTION

|                   |     |      |       |
|-------------------|-----|------|-------|
| 100% Load Prime   | L/h | 50Hz | 9.68  |
| 75% Load Prime    | L/h |      | 7.84  |
| 50% Load Prime    | L/h |      | 5.64  |
| 100% Load Standby | L/h |      | 11.00 |

## EXHAUST SYSTEM

|                                  |                     |      |        |
|----------------------------------|---------------------|------|--------|
| Maximum Temperature 100% Standby | °C                  | 50Hz | 510.00 |
| Exhaust Gas Flow 100% Standby    | m <sup>3</sup> /min |      | 2.71   |
| Maximum Allowed Back Pressure    | mbar                |      | 80.00  |
| Exhaust Flange Size              | mm                  | 51.5 |        |

## AIR SYSTEM

|                                     |                   |      |        |
|-------------------------------------|-------------------|------|--------|
| Intake Air Flow 100% Standby        | m <sup>3</sup> /h | 50Hz | 146.00 |
| Total Cooling Air Flow 100% Standby | m <sup>3</sup> /s |      | 0.80   |
| Alternator Fan Airflow              | m <sup>3</sup> /s |      | 0.20   |

## SOUND PRESSURE (CANOPY ONLY)

|          |      |       |    |
|----------|------|-------|----|
| LpA (7m) | 50Hz | dB(A) | 63 |
|----------|------|-------|----|

## MECHANICAL FEATURES

|                                 |   |
|---------------------------------|---|
| Cooling Pack                    | ● |
| Air Filter                      | ● |
| Mechanical Governor             | ● |
| Low Oil Pressure Switch         | ● |
| Coolant Temperature Sender      | ● |
| Oil Temperature Sender          | ● |
| Radiator Guards                 | ● |
| Hot Component Guards            | Δ |
| Manual Oil Drain Pump (Canopy)  | Δ |
| Water Jacket Heater             | Δ |
| Pre-Filter with Separator       | ● |
| Fuel Level Sender               | ● |
| Internal Fuel Fill (Belly Tank) | ● |
| 3 Way Fuel Valve                | Δ |
| Residential Silencer            | ● |
| Industrial Silencer             | x |

Standard: ●      Not Available: x      Optional: Δ

## ELECTRICAL FEATURES

|  |   |
|--|---|
| AVR DSR                                  | ● |
| AVR DER                                  | x |
| Winding Protection Standard              | x |
| Winding Protection Standard +            | x |
| Winding Protection Grey                  | ● |
| Winding Protection Total                 | Δ |
| Winding Protection Total +               | Δ |
| MAUX                                     | ● |
| PMG                                      | Δ |
| Anti-Condensation Heater                 | Δ |
| 3 Pole Moulded Case Circuit Breaker      | ● |
| 4 Pole Moulded Case Circuit Breaker      | Δ |
| Earth Leakage Protection (Shunt Trip)    | Δ |
| Preparation for Earth Spike              | ● |
| Optional Voltages                        | Δ |
| Remote Screen                            | Δ |
| Emergency Stop Button                    | ● |
| External Emergency Stop Button           | ● |
| Standard: ● Not Available: x Optional: Δ |   |

## BATTERY FEATURES

|  |           |
|--|-----------|
| Battery Isolator                         | Δ         |
| Battery Type                             | Lead Acid |
| Battery Size (Ah)                        | 110       |
| Number of Batteries                      | 1         |
| Battery Charger                          | Δ         |
| Standard: ● Not Available: x Optional: Δ |           |

## JCB COMMUNICATION AND CONTROL

|  |   |
|--|---|
| 4510                                     | x |
| 4520                                     | ● |
| Standard: ● Not Available: x Optional: Δ |   |

## WEIGHT AND DIMENSIONS

|                             |                |         |
|-----------------------------|----------------|---------|
| Length                      | mm             | 2250    |
| Width                       | mm             | 840     |
| Height                      | mm             | 1350    |
| Shipping Volume (sea ready) | m <sup>3</sup> | 2.55    |
| Weight*                     | Kg             | 1000.00 |

\*Standard build with all fluids except fuel

## CE PACK (OPTIONAL)

|  |   |
|--|---|
| EMC Certification                          | ● |
| Hot Guards                                 | ● |
| Belt Guards                                | ● |
| Earth Leakage Relay                        | ● |
| Sound Power Decal                          | ● |
| EU Declaration for Engine Emissions        | ● |
| Complete Machine Declaration of Conformity | ● |
| Standard: ● Not Available: x Optional: Δ   |   |

## REFERENCE STANDARDS

JCB Generators are CE certified and conform to the following Directives (subject to a country requiring such standard):

- EN 12100, EN 13857, EN60204
- 2006/42/CE Machinery safety
- 2006/95/EC Low voltage
- 2004/108/CE Electromagnetic compatibility
- 2000/14/EC Sound Power Level (amended by 2005/88/EC)
- 97/68/EC Emissions(amended by 2002/88/EC & 2004/26/EC)
- Power according to ISO 8528 and ISO 3046
- Ambient reference conditions 1000mbar, 25°C, 30% relative humidity ISO3046

Information based on standard specification equipment unless otherwise stated.